

## oval pressure cover

up to 10/-1 bar overpressure

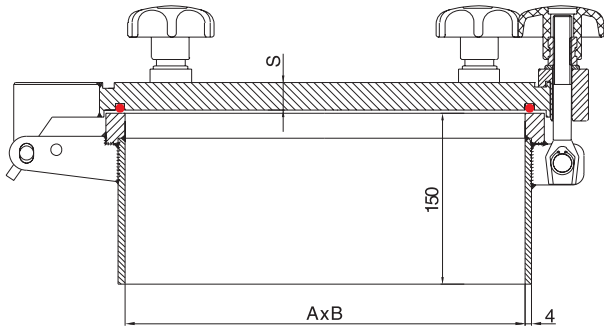

## standard design

- wetted material: ASTM SA-240 316LSS non-wetted: 304SS
- stainless steel handles
- silicone seal (blue)
- with hinge, with handle
- neck height 6" (150 mm), neck thickness 4 mm
- surface unground, pickled

## options

- wetted materials: HC-276, HC-22, HC-2000, Alloy 600, AL6XN Alloy, etc..
- intermediate sizes possible
- variety of seal materials (p.12 - 13)
- surface finishes (shot blasted, pickled or ground to 500 grit)
- neck length up to 2000 mm, neck thickness up to 20 mm
- various handles and screws: stainless steel handle, t-handle, collarnut (p.21)
- cover with swivel feature (p.21)
- cover with wedge for installation on the side of the vessel (p.21)
- locking pin (p.21)
- spring assist (torsion-, disc- or gas-springs) (p.21)
- sightglasses: weld pad type, screw-on type, clamp type
- limit switches
- safety grill and safety cross (p.22)
- non-wetted metal parts in different materials

model #	A	B	max. allowed working pressure in bar	max. allowed working temperature in °C	number of screws M16	overall height	S in 316L SS	weight in kg
2203042506	200	300	4	250	6	170	16	26
2203062506	200	300	6	250	6	175	19	28
2203002506	200	300	10	250	6	180	24	32
2252552506	250	350	4	250	6	170	16	31
2253562506	250	350	6	250	6	175	19	34
2253502508	250	350	10	250	8	180	24	39
2304042806	300	400	4	250	6	170	16	36
2304062506	300	400	6	250	6	175	19	42
2304002510	300	400	10	250	10	180	24	49
2354542506	350	450	4	250	6	180	24	55
2354562508	350	450	6	250	8	180	24	56
2354502512	350	450	10	250	12	180	24	59
2405042508	400	500	4	250	8	180	24	65
2405062510	400	500	6	250	10	180	24	67
2405002512	400	500	10	250	12	180	24	69

Archon Industries, Inc. tel: (845) 368-3600  
 357 Spook Rock Road fax: (845) 368-3040  
 Suffern, NY 10901  
 USA info@ARCHONind.com

seals see page 12/13